

MANEUVERING CLEARANCE AT SWINGING DOORS, ANSI A117.1-03

<p>Clark County Dept. of Develop. Services 4701 W Russell Rd Las Vegas, NV 89118 (702) 455-3000</p>	<p>Boulder City Building Department 401 California Avenue Boulder City, NV 89005 (702) 293-9282</p>	<p>Henderson Bldg &amp; Fire Safety Dept. 240 Water Street Henderson, NV 89015 (702) 267-3650</p>	<p>Las Vegas Building &amp; Safety Dept. 731 S. 4th Street Las Vegas, NV 89101 (702) 229-6916</p>
---	---	---	---

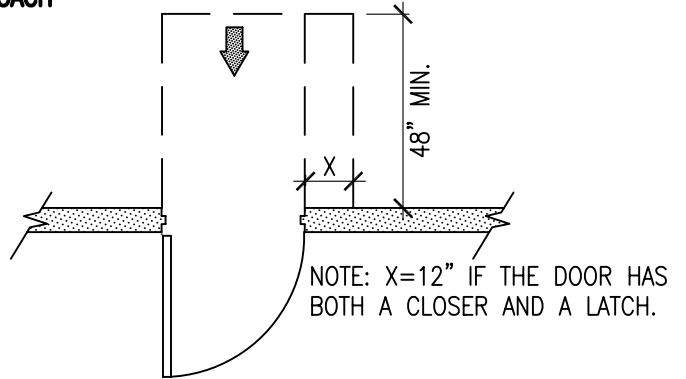

NOTE: ALL DOORS IN ALCOVES SHALL COMPLY WITH THE CLEARANCES FOR FRONT APPROACHES.

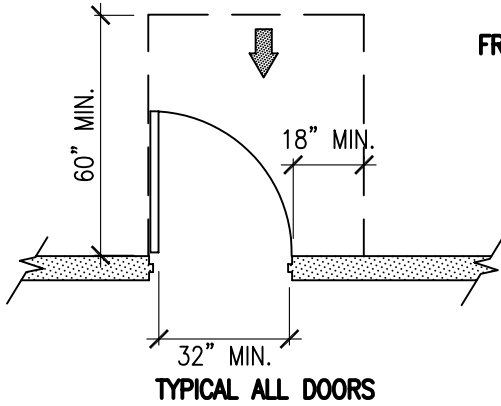
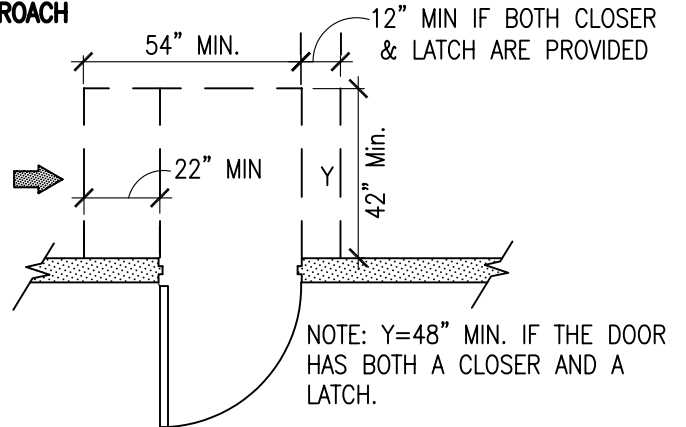
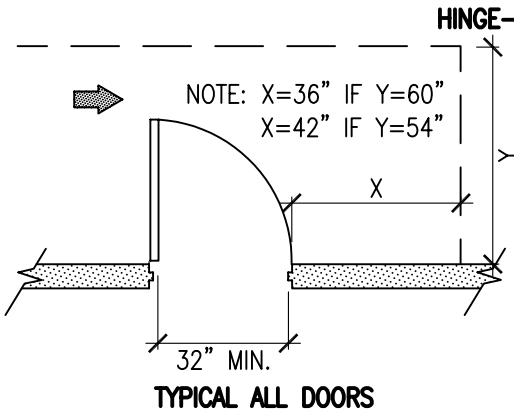

**LATCH-SIDE APPROACH**

NOTE: Y=54" MIN. IF THE DOOR HAS A CLOSER.

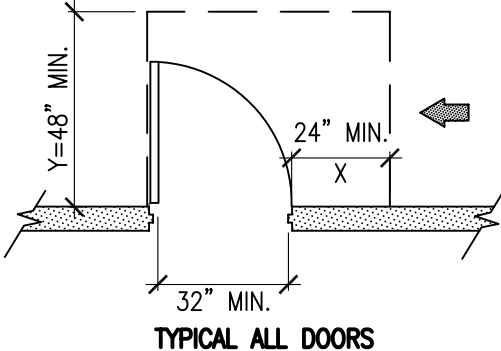

NOTE: Y=48" MIN. IF THE DOOR HAS A CLOSER.

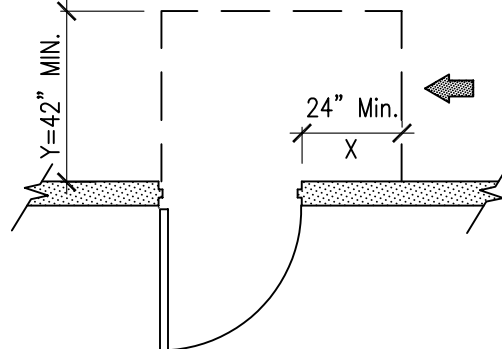

<p>Mesquite Building Department 10 East Mesquite Blvd. Mesquite, NV 89027 (702) 346-2835</p>	<p>North Las Vegas Building Department 2240 Civic Center Drive N. Las Vegas, NV 89030 (702) 633-1577</p>	<p>Pahrump Regional Planning District 1210 E. Basin Avenue, Suite #1 Pahrump, NV 89060 (775) 751-3373</p>	
--	--	---	--